

CU3

Description

The CU3 is a control unit which detects stopped motion and is ideal for use with guard locking interlock switches. It is designed to interface with single or three-phase induction motors by measuring the drive voltage and the back electro-magnetic field (emf) of the motor.



The front window of the CU3 can be popped off to reveal a replaceable fuse and a potentiometer. The potentiometer sets the threshold voltage measured at terminals Z1/Z2. The maximum threshold voltage is approximately 2.5V peak (potentiometer turned fully CCW). When the voltage at Z1/Z2 exceeds the threshold voltage, the safety outputs de-energize, and the safety contacts at terminals 13/14 and 23/24 open.

When the supply to a motor is disconnected, motor speed will reduce to zero. During the run down period the back emf generated by the motor is monitored by the CU3. When the level of the back emf dips below the threshold voltage, the safety outputs close. This enables the output device (e.g., solenoid locking or unlocking switch) to be activated.

If the Z1/Z2 circuit opens, the CU3 goes into a fault state, indicated by the fault led. The fault must be corrected and the power to the CU3 cycled to clear the fault state.

The 24V DC version must be operated with an isolated supply. The CU3 is not intended for use with variable frequency drives.

Features

- Category 1 per EN 954-1
- Stop category 1
- Two N.O. safety outputs
- One N.C. auxiliary output
- Automatic/manual, monitored reset supported
- Motor voltage up to 500V max.

LED Indicators

Red	Power on
Red/Green	Timing/Output On
Yellow	Fault
Red	Motor Running

Specifications

Safety Ratings		
Standards	EN 954-1, ISO 13849-1, IEC/EN 60204-1, IEC 60947-5-1, ANSI B11.19, AS4024.1	
Safety Classification	Cat. 1 per EN 954-1 (ISO 13849-1), SIL CL1 per EN IEC 62061, PL c per ISO 13849-1	
Functional Safety Data * Note: For up-to-date information, visit http://www.ab.com/safety/	PFH _D : See website MTTF _D : See website Suitable for performance levels Plc (according to ISO 13849-1:2006) and for use in SIL3 systems (according to IEC 62061) depending on the architecture and application characteristics	
Certifications	CE marked for all applicable directives, cULus, c-Tick, and TÜV	
Power Supply		
Input Power Entry	24V AC/DC, 115/230V AC	
Power Consumption	<4 VA	
Motor Voltage	500V max.	
Inputs		
Safety Inputs	Z1/Z2 Motor Voltage	
Reset	Automatic/Manual	
Outputs		
Safety Contacts	2 N.O.	
Auxiliary Contacts	1 N.C.	
Rated Impulse withstand Voltage	2500V	
Switching Current @ Voltage, Min.	10 mA/10V	
Fuses, Output	5 A quick acting (external)	
Electrical Life (Operations)	220V AC/4 A/880VA cosφ = 0.35...0.1 M 220V AC/1.7 A375VA cosφ = 0.6...0.5 M 30V DC/2 A/60 W = 1 M 10V DC/0.01 A/0.1 W = 2 M	
Mechanical Life	2,000,000 operations	
Utilization Category		
Inductive: B300: AC-15	5 A @ 250V AC	5 A @ 120V AC
Inductive: DC-13	3 A/24V DC	
Environmental and Physical Characteristics		
Enclosure Type Rating/ Terminal Protection	IP40, DIN 0470/ IP20 DIN 0470	
Operating Temperature [C (F)]	-10...+55 ° (14...131 °)	
Vibration	0.75 mm (0.30 in) peak, 10...55 Hz	
Shock	30 g, 11 ms half-sine	
Mounting	35 mm DIN Rail	
Weight [g (lb)]	510 (1.12)	
Conductor Size, Max.	1 x 2.5 mm ² (14 AWG) stranded, 1 x 4 mm ² (12 AWG) solid	

* Usable for ISO 13849-1:2006 and IEC 62061. Data is based on the following assumptions:
- Mission time/Proof test interval of 20 years
- Functional test at least once within six-month period

Product Selection

Safety Outputs	Auxiliary Outputs	Power Supply	Terminals	Reset Type	Cat. No.
2 N.O.	1 N.C.	24V AC/DC*	Fixed	Monitored Manual, Automatic/Manual	440R-S35001
2 N.O.	1 N.C.	110V AC			440R-S35002
2 N.O.	1 N.C.	230V AC			440R-S35003

* The 440R-S35001 requires an isolated supply when operating on 24V DC.

Accessories

Description	Cat. No.
500 mA fuse—Bussmann Cat. No. ETF-500 mA	440R-A31562

Application Details

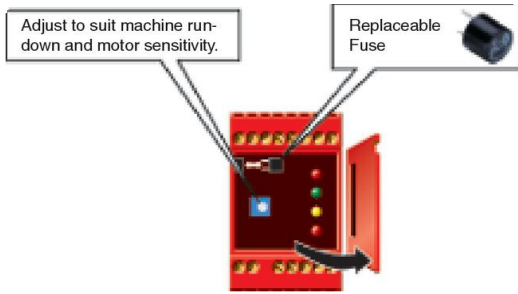

Approximate Dimensions

Dimensions are shown in mm (in.). Dimensions are not intended to be used for installation purposes.

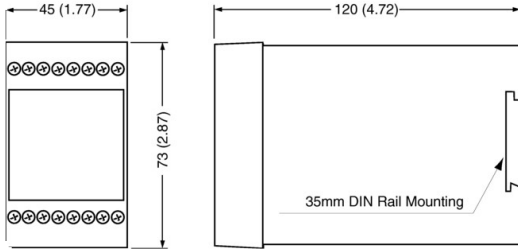

Block Diagram

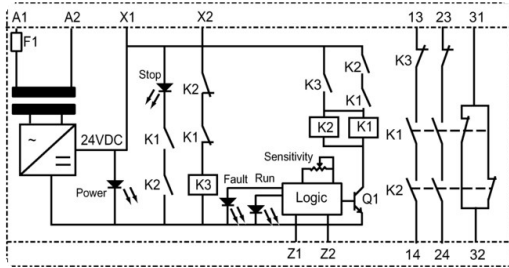

Typical Wiring Diagrams

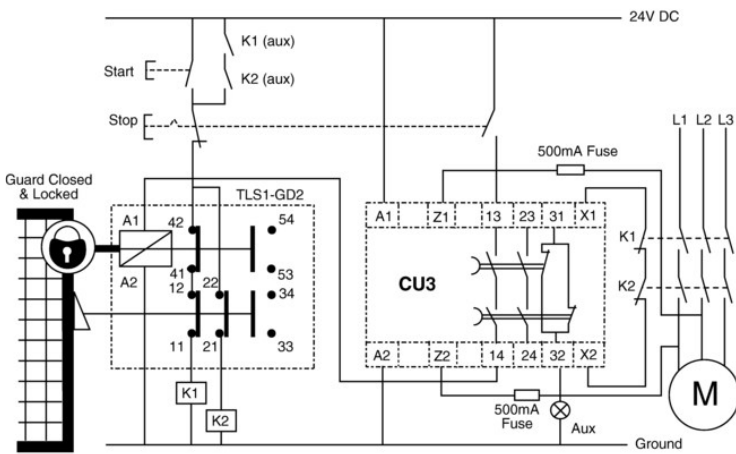

Guard Locking Safety Gate, Back EMF Detection, Automatic Reset, Monitored Output